

Mirosalva S. Bogorad

**ANALYSIS OF THE DYNAMICS OF MECHANICAL DRIVE SYSTEMS
AND ITS IMPACT ON THE PERFORMANCES OF ANTENNA PARABOLIC
SYSTEM (APS) AT THE DESIGN STAGE**

Master's Program Automation of design and engineering

The abstract of the Master's Thesis

Krasnoyarsk 2014

The thesis work is done at the Federal State Autonomous Educational Institution of Higher Professional Education «Siberian Federal University»

Scientific supervisor:

Gerold N. Limarenko, Ph.D. in engineering, Associate Professor

Peer Reviewer:

Petr F. Volkov, Supervisor of design office 1, OAO “Radiosvyaz”

The thesis defence will take place on July 9, 2014 at Siberian Federal University, venue: 26, Academician Kirenskogo Street, Krasnoyarsk, 660074, Russia

Master’s Program Leader:

Ph.D. in engineering,
Associate Professor

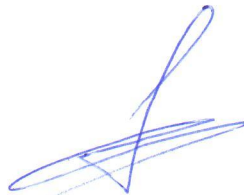

Michail. P. Golovin

GENERAL DESCRIPTION OF THE THESIS WORK.

Significance of the work. The demand for satellite communication systems has been growing since 2007 and it continues to grow up to this day. Traditional communication systems that operate in the so-called C-and Ku-bands at the moment are almost fully loaded and so we must use new frequency resources in higher ranges. Ka-band is considered to be the most affordable resource at the moment. Frequency resource of this range is higher than for C-and Ku-band, but a high frequency range requires a higher precision of antenna pointing.

Analyzed antenna module LD100D-A (Fig. 1) is based on the antenna module operating in Ku-band, which is currently under development at the "Radiosvyaz" plant and does not provide the required pointing accuracy for a range.

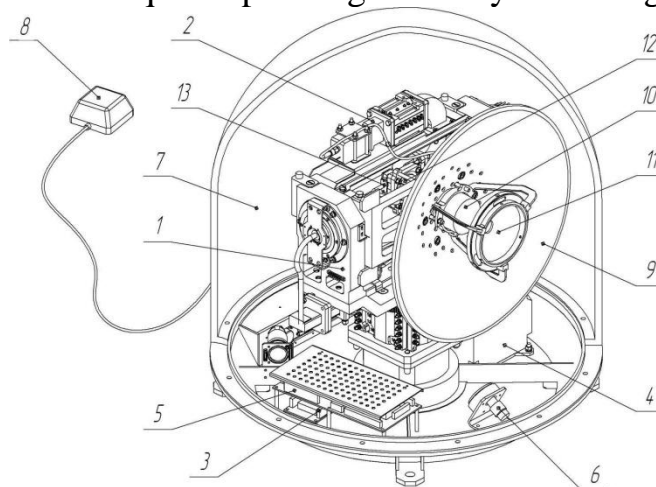

Figure 1 – A general view of an antenna module LD100D-A

For the transition to the higher frequency range accuracy requirements become more tighten. A series of factors affect the accuracy, such as design, technology and manufacturing. Also these factors include high values of the vibration amplitudes. In LD100D-A, for the required accuracy, precision made by the vibrations must not exceed 6 arc minutes.

The object of the thesis is the mechanism of pointing of an antenna module LD100D- A in azimuth and horizon.

The aim of master's thesis is to reveal the component creating the highest precision, for justification of constructive changes of the drive of the antenna system.

The objectives of the research are the following:

- 1) To carry out the information review of a design and the search of patents in a thesis.
- 2) To develop a dynamic model of the systems of drives of movement of the antenna on an azimuth and the horizon.
- 3) To perform calculations and analysis of the dynamic characteristics of drives.
- 4) To model the dynamics of the APS using the software package ANSYS.
- 5) To develop recommendations to improve the dynamic characteristics of the AU.

Research methods:

The following methods were applied to solve the determined tasks:

- The method of finite-element analysis of antenna drives dynamics;
- Methods for modeling the stress-strain state of the elements of the system in the CAE environment;

Reliability of the data is determined by the selected methods, and solution of test problems.

Scientific novelty of this work:

1) The basic structural elements affecting the pointing accuracy of the horizon and azimuth mirror reflector were found, and dynamic models for the analysis of fluctuations AS for steady motion were developed.

2) A method for determining the elastic dynamic parameters of APS drives at the design stage was created, combining engineering calculations and instrumental analysis of the stress-strain state.

Practical significance

Using results of the study of dynamic characteristics, the proposals on improving the quality of the dynamic mechanism of the antenna system were made.

Work approbation:

1. Research and practical conference “Youth and Science” (Siberian Federal University, Krasnoyarsk, 2013);

2. The Xth international student research and practical teleconference «Scientific community of the 21st century students» (Novosibirsk 2013);

3. Workshops of the department of design - engineering support of machinery production (Polytechnic Institute, Siberian Federal University).

THE CONTENT OF THE WORK

Introduction shows the relevance of the studying the problem of high values of amplitudes of mechanism vibrations. It gives a general characteristic of the problem.

Chapter 1 is devoted to review and analysis methods for studying the dynamic characteristics. We considered tools for the task, and made the following conclusions:

- 1) The study should combine theoretical methods using software systems.
- 2) The requirements of accuracy and performance specification antennas were considered.
- 3) The technique for further calculations is chosen.
- 4) A search of patents and scientific literature on the subject matter of the thesis was done.

Chapter 2 is devoted to the considering and identifying structural components of interacting drives affecting the pointing accuracy of the horizon and azimuth of a

mirror reflector and developing dynamic models for the analysis of fluctuations AU for steady motion and identifying their characteristics.

A global coordinate system is a system of coordinates where the Z-axis is normal to the surface and is the center of the rotational motion of the antenna device when pointing in the horizontal direction is parallel to the XY plane of the earth's surface, the Y axis is parallel to the axis of rotation of the antenna head, and the X axis is side of the mirror antenna (Fig. 1).

Figure 2 shows a simplified model of APS used in the calculation of its inertial mass characteristics.

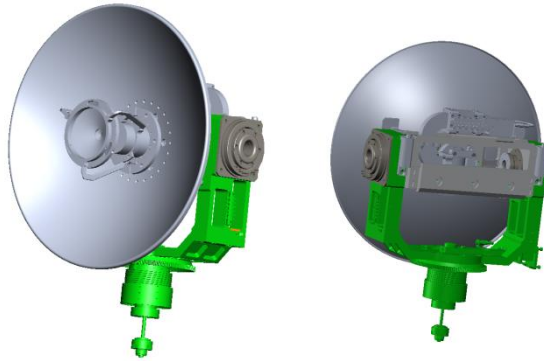

Fig. 2 – a simplified model of an antenna system

For the equations of motion mass elements m_1 and m_2 were chosen as the basic parts. M_1 is referred to the component part of the mechanism that performs a rotation around the Z axis with the antenna pointing system, and refers to the component m_2 as the part that performs a rotation around the axis Y.

The main part of the first mass component is gear, bearing supports and the bracket that supports the base of the antenna system (Fig. 3).

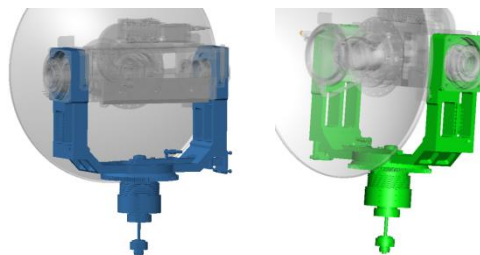

Fig. 3 – the first mass component

The main part of the second mass component is tooth gearing, bearing support and the arm supporting the basis of the antenna system (Fig. 4).



Fig. 4 – the second mass component

Fig. 5 shows the dynamic model of the AS to analyze its vertical (axis Z) and angular vibrations (axis Y). The model does not indicate damping components that operate parallel to stiffeners.



Рис. 5 – the dynamic model of vertical and angular vibrations

To investigate the mechanism of the model the antenna pointing system has been simplified and is relieved from all additional components that do not participate in the rotation axes and vibrational motions.

The kinetic energy of a conservative system:

$$T = \frac{1}{2} [m_1 \dot{z}_1^2 + J_1 \dot{\phi}_1^2 + m_2 \dot{z}_2^2 + J_2 \dot{\phi}_2^2], \quad (1)$$

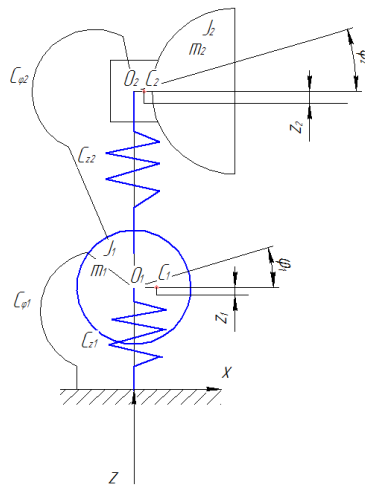
$$\text{где } \dot{z}_1 = \dot{z}_{01} + L_{01c1} \dot{\phi}_1; \quad \dot{z}_2 = \dot{z}_{02} + L_{02c2} \dot{\phi}_2.$$

After the conversion (1)

$$2T = m_1 \dot{z}_{01}^2 + 2m_1 L_{01c1} \dot{z}_{01} \dot{\phi}_1 + m_1 L_{01c1}^2 \dot{\phi}_1^2 + m_2 \dot{z}_{02}^2 + 2m_2 L_{02c2} \dot{z}_{02} \dot{\phi}_2 + m_2 L_{02c2}^2 \dot{\phi}_2^2 + J_1 \dot{\phi}_1^2 + J_2 \dot{\phi}_2^2. \quad (2)$$

The potential energy of a conservative system:

$$V = \frac{1}{2} [C_{z1} z_{01}^2 + C_{\phi1} \phi_1^2 + C_{z2} (z_{01} - z_{02})^2 + C_{\phi2} (\phi_1 - \phi_2)^2]. \quad (3)$$

After the conversion (3)

$$2V = (C_{z1} + C_{z2}) z_{01}^2 + (C_{\phi1} + C_{\phi2}) \phi_1^2 + C_{z2} z_{02}^2 + C_{\phi2} \phi_2^2 - 2C_{z2} z_{01} z_{02} - 2C_{\phi2} \phi_1 \phi_2. \quad (4)$$

Inertia and stiffness matrices of the system obtained in (1) - (4):

$$A = \begin{bmatrix} m_1 & m_1 L_{o1c1} & 0 & 0 \\ m_1 L_{o1c1} & J_1 + m_1 L_{o1c1}^2 & 0 & 0 \\ 0 & 0 & m_2 & m_2 L_{o2c2} \\ 0 & 0 & m_2 L_{o2c2} & J_2 + m_2 L_{o2c2}^2 \end{bmatrix}$$

$$C = \begin{bmatrix} C_{z1} + C_{z2} & 0 & -C_{z2} & 0 \\ 0 & C_{\varphi1} + C_{\varphi2} & 0 & -C_{\varphi2} \\ -C_{z2} & 0 & C_{z2} & 0 \\ 0 & -C_{\varphi2} & 0 & C_{\varphi2} \end{bmatrix}$$

Vectors

$$\ddot{q} = \{ \ddot{z}_{01} \ \ddot{\varphi}_1 \ \ddot{z}_{02} \ \ddot{\varphi}_2 \}.$$

$$q = \{ z_{01} \ \varphi_1 \ z_{02} \ \varphi_2 \}.$$

Fig. 6 shows the dynamic model of the AU at its torsional vibrations around the axis Z. The kinetic and potential energy of a conservative system is represented in the form of equations

$$T = \frac{1}{2} (J_1 \dot{\varphi}_1^2 + J_2 \dot{\varphi}_2^2), \quad (5)$$

$$J_1 = J_{c1} + m_1 L_1^2$$

$$J_2 = J_{c2} + m_2 L_2^2$$

$$2T = J_{c1} \dot{\varphi}_1^2 + m_1 L_1^2 \dot{\varphi}_1^2 + J_{c2} \dot{\varphi}_2^2 + m_2 L_2^2 \dot{\varphi}_2^2 \quad (6)$$

$$V = \frac{1}{2} [C_{k1} \varphi_1^2 + C_{k1} (\varphi_1 - \varphi_2)^2] \quad (7)$$

$$2V = (C_{k1} + C_{k2}) \varphi_1^2 + C_{k2} \varphi_2^2 - 2C_{k2} \varphi_1 \varphi_2 \quad (8)$$

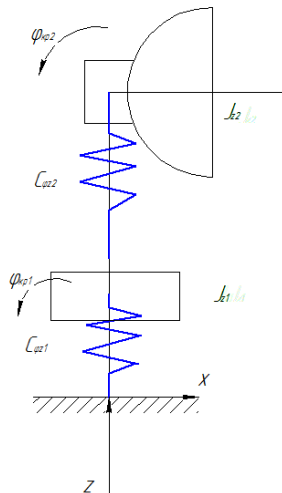

Fig. 6 – the dynamic model of the AS at its torsional vibrations around the axis Z

Matrix of inertia and stiffness matrix of the system are obtained by differentiating (5) - (8)

$$\begin{bmatrix} J_{c1} + m_1 L_1^2 & 0 \\ 0 & J_{c2} + m_2 L_2^2 \end{bmatrix}$$

$$C = \begin{bmatrix} C_{k1} + C_{k2} & -C_{k2} \\ -C_{k2} & C_{k2} \end{bmatrix}$$

To solve this system of equations we require input data in the form of mass-inertial characteristics of the system components and elastic connections between them. The moments of inertia are defined in the Solid Works. For natural frequencies it is necessary to determine the stiffness of the system of connections.

Chapter 3 is devoted to Eigen frequencies and amplitude of the forced vibrations of the system based on the modal analysis using data obtained in the previous section. Eigen frequencies of the system are given in Table 1

Table 1 – Eigen frequencies of the system

	Axial vibration along the Z axis	Rotation around the Y axis	Rotation around the Z axis
First frequency, Hertz	20.1	30.2	18.77
Second frequency, Hertz	338.114	151.4	54.22

Values of the vibration amplitudes for two components of the mechanism of mass relative to the two resonant frequencies are shown in Figure 7 and Figure 8.

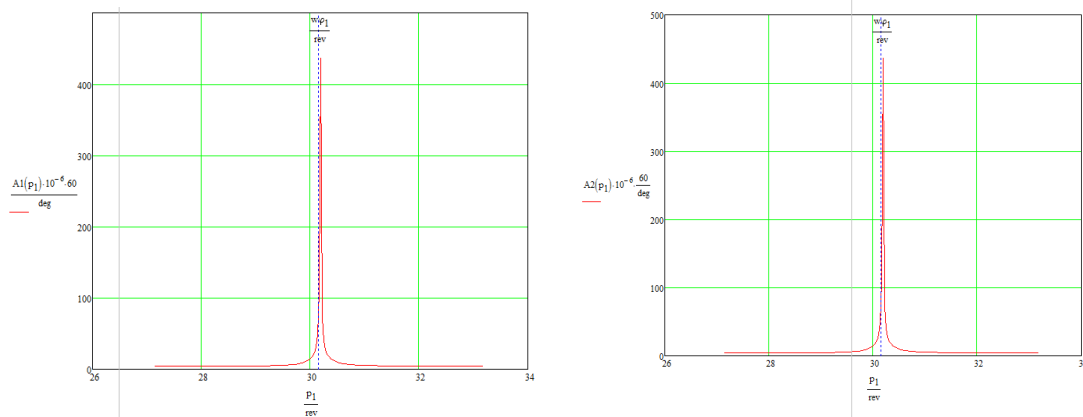

Fig.7 – the 1-st Eigen frequency for Y vibrations

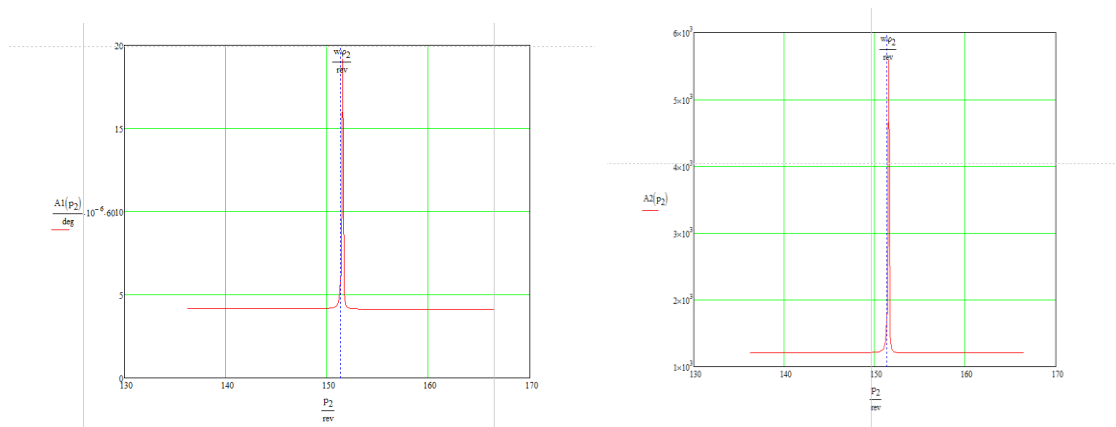

Fig.7 – the 2-nd Eigen frequency for Y vibrations

The data for the other coordinates was processed too. Obtained values are calculated at the bottom point of the reflector antenna base. Summary data are shown in Table 2:

Table 2 - The amplitudes of vibrations are given to the mirror base

	Axial vibration along the Z axis	Rotation around the Y axis	Rotation around the Z axis
Vibration amplitude at a first frequency, microns	26.404	56.67	15.121
Vibration amplitude at a second frequency, microns	0.293	2.494	0.943

Chapter 4 is devoted to the evaluation of the results of calculation and studying possible changes in the design of the object in order to improve its quality.

From Table 3 the weaknesses in the design could be identified.

The lowest values of stiffness in torsional vibrations around the Y axis show the bracket in the first component and antenna base in the second component. Furthermore, stiffness of the first component is twice smaller in comparison with stiffness of the second one.

Table 3 - Summary table of the spring stiffness in the system

		First mass element			Second mass element		
Rotation around the Y axis	$N \cdot \frac{m}{rad}$	$C_{\varphi1вал}$	$C_{\varphi1кр}$	$C_{\varphi1}$	$C_{подш1}$	$C_{кронш1}$	C_{z1}
		$19,9 \cdot 10^3$	$5,21 \cdot 10^3$	$4,13 \cdot 10^3$	$44,46 \cdot 10^5$	$6,7 \cdot 10^5$	$5,83 \cdot 10^5$
Axial, along the Z		$C_{подш1}$	$C_{кронш1}$	C_{z1}	$C_{подш2}$	$C_{основ2}$	C_{z2}
		$44,5 \cdot 10^5$	$6,7 \cdot 10^5$	$5,83 \cdot 10^5$	$459,8 \cdot 10^5$	$844,6 \cdot 10^5$	$297,7 \cdot 10^5$
Rotation around the Z axis		$C_{кр1}$	$C_{\varphi zk1}$	$C_{\varphi z1}$	$C_{\varphi z2подш}$	$C_{\varphi z2осн}$	$C_{\varphi z2}$
		$8,24 \cdot 10^3$	$55,8 \cdot 10^3$	$7,18 \cdot 10^3$	$4,271 \cdot 10^5$	$9,61 \cdot 10^3$	$9,4 \cdot 10^3$

For axial vibrations relative to the axis Z the first arm member and the second bearing member are the weak points, the stiffness of the second member is about 50 times higher than stiffness of the first one.

Toothings and bearings of the second component have the smallest rigidity values in torsional vibrations around the Z axis.

From Table 4 we can see that the specified accuracy in 6 minutes of arc does not correspond to the amplitude of the vibrations at the first resonant frequency in rotation about the axis Z.

Table 4 - Vibration amplitude in arc minutes

	Axial vibration along the Z axis	Rotation around the Y axis	Rotation around the Z axis
Vibration amplitude at a first frequency, minutes	1,4	3	8
Vibration amplitude at a second frequency, minutes	0,015	0,0022	0.05

From the analysis of stiffness it can be seen that gear has the lowest stiffness and it is a weak link mechanism. To improve the dynamic characteristics a mechanical drive should be replaced by an electromechanical one.

We recommend driving the rotation of the antenna on the horizon and developing the design of the flat stepped motor based on the permanent magnets.

Conclusion

1 Scientific literature and patents relating to the dissertation were reviewed.

2 A dynamic model of the drive system moving the antenna in azimuth and horizon was developed.

3 The inertial-mass characteristics of a parabolic antenna, given to the generalized coordinates were determined.

4 The calculation and analysis of the dynamic characteristics of the drive was performed.

5 Modeling of the dynamics of the AS in the software package ANSYS was performed.

6 Replacing a mechanical drive by an electromechanical one is recommended.

The main publications on the theme of the thesis:

1. Bogorad M. S. Using CosmosWorks for measuring deformation values used in the calculation of natural frequencies and amplitudes of the oscillations of the antenna system // proceedings of the Xth international student research and practical teleconference «Scientific community of the 21st century students» (Novosibirsk 2013).

2. Bogorad M. S. To the choice of methodology for calculating dynamic characteristics of bearing turning gear in antenna systems // proceedings of research and practical conference “Youth and Science” (Siberian Federal University, Krasnoyarsk, 2013)

3. Bogorad M. S. Analysis of the methods for calculating the natural frequencies and vibration amplitudes, applicable to the mechanisms of antenna systems // proceedings of research and practical conference “Youth and Science” (Siberian Federal University, Krasnoyarsk, 2013).

4. Bogorad M.S. Dynamic modeling of the parabolic antenna device for the subsequent calculation of its dynamic characteristics / / International Research Journal: Collected by the results of the scientific conference VII Research Journal of International Studies. Yekaterinburg. : MNIZH - 2014. - № 6 (25)